

SR05-24-01 Sliding Rail Installation

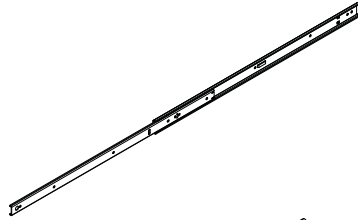

Included in this package

(2) 24" Sliding Rail



(2) Rear Ear Bracket w/o standoff

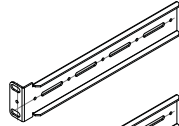

(2) Front Ear Bracket w/standoff

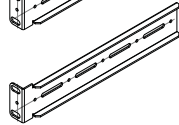

(20) M4 x 8 Screws and (6) M4 nuts



(8) #10-32 x 5/8 Screws



(8) #12-24 x 5/8 ScrewsHead



Installation Steps

- 1 Holding the 24" sliding rail on one hand then pull the center slide (traveling slide) all the way out until it stops. You will see a metal clip at the end point of center slide. Pushing down the metal clip to unlock the center slide.

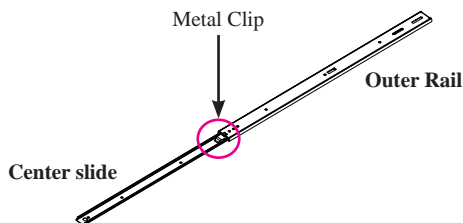

- 2 Mounting the front ear bracket as show in the picture below. Adjusting the front ear bracket according to the mounting position you want in your cabinet. The first screw hole is the default mounting position. Secure the outer slide to front ear bracket with a M4 screw included.

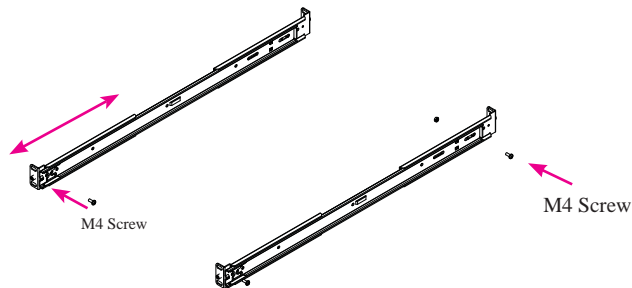

- 4 Attach the front ear bracket with rail on to the cabinet as show below. Use included rack screws to secure front and back ear bracket on to cabinet. Tighten all M4 screws on the outer rail.

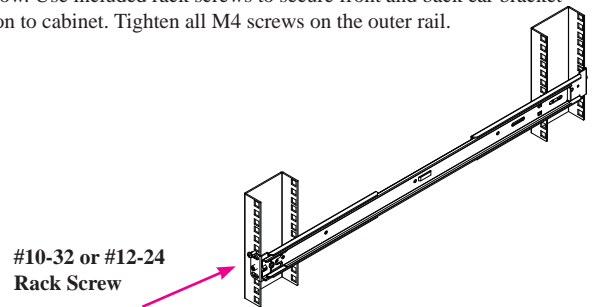

5. Repeat Step 1 to 4 for right hand side rail and ear bracket.

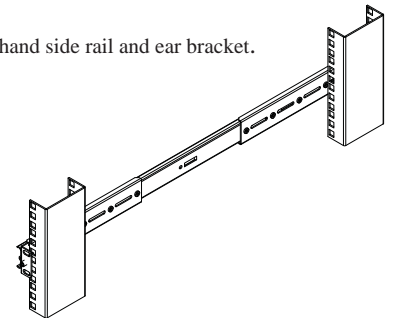

- 3 Mounting the rear ear bracket to rear side of rail. Adjust the rear ear bracket according to depth of your cabinet. If a screw hole is available, secure ear bracket to outer rail with a M4 screw. If only open slot is available, secure rear ear bracket with outer rail with M4 screw and M4 nuts. Do not tighten screw yet.

- 6 Attaching center rail to right side of your equipment. Make sure at least 2 screw holes are aligned. Secure center rail to shelf with M4 screws to complete your installation.

